

Composite drums



07.04 E

Advantages

- UN homologation for fluid dangerous goods
- Compliance with 94/62 EC
- Coatings also can comply with EC 1895/2005, AP 96 (5) EC, BAG, BGA, FDA, EU 90.128/EEC
- Fully drainable
- No problems with material separation due to special construction

Construction

Tight head composite drum:

- Container blow - moulded polyethylene inside with 2" bungs
- Body overlapped welded, bottom/top seamed to body with injected sealing compound
- ODD version enables the drum to empty leaving less residue than a standard drum

Open head composite drum as above but additionally:

- Jet-Ring closing ring galvanized, tamper evident mounted in the outer lever handle, lid with PU sealing

After emptying the drum, the metal lid may be separated from the PE container by using a special gripper tool. After separation, the metal container can be used a second time or reconditioned to a composite drum.



Materials

- Mild steel St. 12.03 galvanized or stainless steel
- Container inside PE

Closures

- 2" polypropylene with rubber or PE sealing ring with inner 3/4" available

Surface treatment

- Galvanized or lacquered
- Optional lacquer lining inside/outside for aggressive chemicals
- Exactly suitable for your products
- On line silk screening on body and top available

Remarks

- Standard rolling hoop can be reduced to 585 mm in order to facilitate containerisation
- Designed for optimum strength and volume
- Very secure packaging
- Rational filling and handling

Quality management

- ISO 9001:2000



Müller Ltd Packaging
Tramstrasse 20
CH-4142 Münchenstein 1

A Company of the Müller-Group
www.mueller-group.com

Phone: ++41(0)61/4161200
Fax: ++41(0)61/4161222
Internet: www.muellerdrums.com
E-mail: info@muellerdrums.com

Technical information



07.04 E

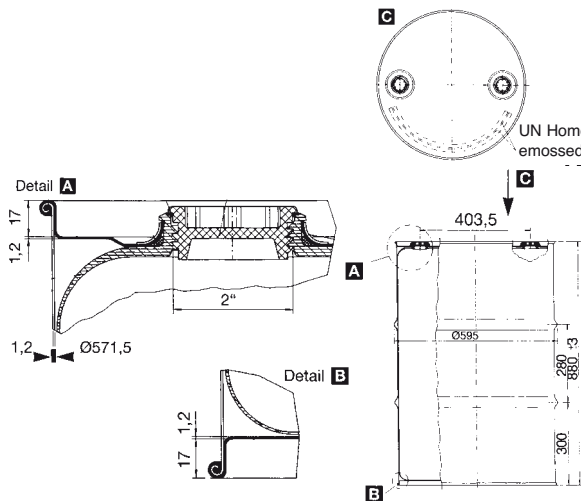

This example shows a composite drum 205 liters

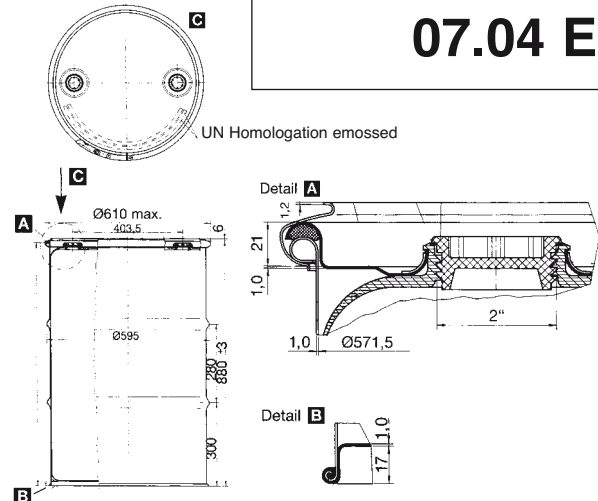

This example shows an open head, composite drum 205 liters

Tight head composite drum

Capacity Ltr.	Diameter mm	Thickness mm Bottom/Body/Top	UN Marking	Remarks
30	305 / 295	0,5 / 0,5 / 0,5	UN 6HA1/X/280../CH2065	0,530 kg HDPE
30	305 / 295	0,75 / 1,0 / 0,75	UN 6HA1/X1.8/280../CH/EGI-3227	0,530 kg HDPE
60	385 / 372	0,6 / 0,6 / 0,6	UN 6HA1/X/280../CH2066	1,0 kg HDPE
60	385 / 372	1,0 / 1,0 / 0,75	UN 6HA1/X2.0/350../CH/EGI-3228	1,5 kg HDPE
117	463 / 444	1,0 / 1,0 / 1,0	UN 6HA1/X1.7/550../CH2088	2,0 kg HDPE 3,6 kg HDPE (optional)
205	571,5	1,2 / 1,2 / 1,2	UN 6HA1/Y/280../CH2027	3,0 kg HDPE
205	571,5	1,2/ 1,2 / 1,2	UN 6HA1/X2.0/250../CH/2150 DOT 6D / 18-55-M	4,0 kg HDPE DOT-2SL PAG
205	571,5	1,0 / 0,9 / 1,0	UN 6HA1/X1.8/300../CH/EGI-4204661	3,6 kg HDPE
205	571,5	1,0 / 1,0 / 1,0	UN 6HA1/Y/280../CH2089 DOT 6D / 20-55-M	3,0 kg HDPE DOT-2SL PAG
205	571,5	1,0 / 1,0 / 1,0	UN 6HA1/X2.0/350../CH2026 DOT 6D / 20-55-M	3,6 kg HDPE DOT-2SL PAG
205	571,5	1,5 / 1,2 / 1,5	UN 6HA1/X2.0/250../CH2362 DOT 6D / 20-16-55-M	3,6 kg HDPE DOT-2SL PAG
205	571,5	1,0 / 1,0 / 1,0	UN 6HA1/X2.0/350../CH/EGI-3623	3,6 kg HDPE super clean
205	571,5	1,2 / 1,2 / 1,2	UN 6HA1 W/X2.0/350../CH/EGI-3892	3,6 kg HDPE

Open head composite drum

Capacity Ltr.	Diameter mm	Thickness mm Bottom/Body/Top	UN Marking	Remarks
58	400	0,6 / 0,6 / 0,6	UN 6HA1/Y100../CH2190	1,0 kg LD PE
205	571,5	1,0 / 1,0 / 1,0	UN 6HA1/X1,6/280../CH2876	3,0 kg HD PE DOT-2SL PAG JET-RING

Other sizes and design upon request

For more information please contact us and ask for detailed technical documentation

Müller Ltd Packaging
Tramstrasse 20
CH-4142 Münchenstein 1

Phone: ++41(0)61/4161200
Fax: ++41(0)61/4161222
Internet: www.muellerdrums.com
E-mail: info@muellerdrums.com

A Company of the Müller-Group
www.mueller-group.com